



ARTS COMMISSION

Monday, October 9, 2023

Council Chambers

505 Forest Avenue, Laguna Beach, CA 92651

5:00 P.M.

- A G E N D A -

- 1) Call to Order
- 2) Approval of Minutes
- 3) Chair's Announcements (Ballard)
- 4) Commissioner, Council and Staff Communications
- 5) Public Communications - *To assist the Arts Commission in the timely completion of its business, speakers are asked to limit their presentation to three minutes or less.*
- 6) Items for Discussion and Action:
 - A. **Art in Public Places - 1369 North Coast Highway** – Discuss and approve the installation of the sculpture “Sea Breeze Symphony” by Rahul Jobalia to satisfy the Art in Public Places requirement of the Municipal Code. (Commissioner: Schwerner, Staff Wood.)
 - B. **Holiday Palette Competition**– Discuss and select up to four designs or reject all entries. (Commissioner Kollenda, Staff: McGregor)
- 7) Adjournment
Pursuant to the Americans with Disabilities Act, persons with a disability who require a disability-related modification or accommodation to participate in a meeting, including auxiliary aids or services, may request such modification or accommodation from the Arts Manager at 949-497-0722 or email art@lagunabeachcity.net. Notification 48 hours prior to the meeting will enable the City to make reasonable arrangements to assure accessibility to the meeting.

cc: City Manager, City Clerk, Council Liaison Mayor Pro-Tem, Director Transit and Community Services

Post through October 10, 2023



LAGUNA BEACH ARTS COMMISSION

Regular Meeting

Monday, September 25, 2023

Council Chambers

505 Forest Avenue, Laguna Beach, CA 92651

5:00 p.m.

Recap of Minutes

PRESENT: **Commissioners:** Donna Ballard, Austin Barrow, Suzi Chauvel, Michael Ervin, Pat Kollenda, Michael Ray, Adam Schwerner, and Carl Smith.
STAFF: Sian Poeschl, Cultural Arts Manager, Michael McGregor, Arts Program Coordinator, Karen Wood, Public Art Coordinator, Michael Litschi, Director of Transit and Community Services.
COUNCIL: Mayor Pro-Tem Sue Kempf

- 1) Donna Ballard called the meeting to order at 5:00 p.m.
- 2) The minutes of the September 11, 2023, meeting were approved as presented. M/S Kollenda/Chauvel.
- 3) **Chair's Announcements:** None.
- 4) **Commissioner and Staff Communications:** Pat Kollenda congratulated Staff Poeschl on 26 years of employment with the City. Staff Wood noted attending the fallen officer memorial service. Staff McGregor noted a successful Sunset Serenades concert on September 22, 2023, and the Juried Fine Art exhibition had been installed at City Hall. Staff Poeschl noted the joint City Council and Arts Commission meeting would be rescheduled to February 27, 2024. Staff noted that the meeting on October 23 had been cancelled due to lack of agenda items. Staff noted artist Beau Stanton would begin his installation of "Coalescence" at the flood channel walkway on October 2, 2023. Staff noted Pacific Symphony had been promoting their concert at Heisler Park on October 6, 2023. Staff Poeschl thanked Staff McGregor and Wood for their work coordinating concerts and public art restorations. Mayor Pro-Tem Kempf commended the mural "Super Natural Bloom" by DABSMYLA.
- 5) **Public Communications:** None.
- 6) Items for Discussion and Action:
 - A) **Art in Public Places – 1369 North Coast Highway** – Property representative Neel Desai described the proposal, presented visual samples, and introduced artist Rahul Jhobalia. Mr. Jhobalia described the proposed sculpture materials of ribboned stainless steel. Donna Ballard noted rust and maintenance issues with a recent City public artwork originally made of the same material. Pat Kollenda requested actual material samples. The Commission requested the artist return with a defined singular proposal instead of a general concept. The item was continued.
 - B) **Youth Art Advisory Board** – Staff McGregor presented the statements of interest and relevant experience of the Youth Art Advisory Board applicants. A motion was made to appoint Hannah Miller, Charley Jerabek, and Luci Pina to the Youth Art Advisory Board. M/S Kollenda/Ervin. Yeas: Ballard, Barrow, Chauvel, Ervin, Kollenda, Schwerner, Smith. Noes: None.
- 7) Adjourned at 5:30 p.m.

cc: City Manager, City Clerk, Mayor Pro-Tem Kempf, Director of Transit and Community Services

**City of Laguna Beach
Cultural Arts Department
Staff Report**

To: Arts Commission
From: Karen Wood, Public Arts Coordinator
Agenda Item: 6A
Title: 1369 North Coast Highway Art in Public Places Application

Overview

The property located at 1369 North Coast Highway is a new commercial and industrial building being developed by TLB LLC who have elected to install artwork to satisfy the Municipal Code requirement of Chapter 1.09 Art -in Public Places. ([LINK to the Municipal Code](#))

Summary of the Matter

The artwork entitled “Sea Breeze Symphony” is a sculpture consisting of multiple interwoven two-inch stainless-steel ribbons primed and spray painted with metallic paint. The sculpture by artist Rahul Jobalia will measure 5 feet in height by 7 feet 4 inches in width by 6 inches in depth, mounted 12 inches from the ground on an exterior cement wall facing North Coast Highway. The sculpture will have a 2-inch top and bottom anchoring system made of galvanized stainless steel with additional anchoring into the wall. The sculpture will be finished in turquoise, orange, and steel patina, with a gloss finish. Each of these three ribbons represents a different aspect of Laguna Beach’s character as described in the application. The sculpture will be lit by existing LED lighting. Maintenance will be facilitated by the property owner and is anticipated to be cleaning and refreshing the paint every 5-7 years as needed.

Update

Neel Desai and Rahul Jobalia, Artist, presented the proposal to the Arts Commission on September 25, 2023. The matter was continued. The Arts Commission asked the applicant to return with a representative small-scale model in the proposed materials and requested additional details of past similar work by the artist. The September 29, 2023 submission herein includes more detailed information of the proposed installation, but not the artist’s previous works. The updated application proposes a single metallic color rather than the three colors previously noted. Mr. Desai indicated they will bring the model with them to present and answer remaining questions at the October 9, 2023 Arts Commission meeting.

Recommendation:

It is recommended that the Arts Commission hear the updated presentation and consider the application.

ART IN PUBLIC PLACES APPLICATION FORM

Chapter 1.09 of the Municipal code describes the intent and purpose of the Laguna Beach Art in Public Places program. Please see pages 1-4.

The requirements of chapter 1.09 apply to the following types of projects. Please check the type which describes your project:

- A. New commercial and industrial development.
- B. Residential development (including subdivisions) of more than four lots or units.
- C. Remodeling, repair, or reconstruction of buildings in the above two categories when the value exceeds \$225,000.00.
- D. Certain City public works projects when the value exceeds \$225,000.00.

Address of project: 1369 North Coast Highway

Description and proposed use of structure: See attached description of artwork

Developer: TLB LLC

Contact Person: Neel Desai

Address: 801 Parkcenter Dr. Ste 100 Santa Ana, CA 92705

Phone: 714-600-5116

Name of Owner: TLB LLC Phone: 714-940-0030

Address of Owner: 801 Parkcenter Dr. Ste 100 Santa Ana, CA 92705

Expected date of occupancy: September 28th, 2023

Two options are available for complying with the Art in Public Places program. Please indicate below the option you have selected.

- Paying an in-lieu fee which is a contribution to the Art In-Lieu fund and will be equal to 1.25% of the total project valuation; or
- Acquiring and installing an art work on the project site which is of at least 1% of the total project valuation.

Please complete this form and contact the staff Liaison to the Laguna Beach Arts Commission at 497-0722 if you plan to install an art piece at the project site.

The in-lieu fee must be paid by the project applicant at the time of final subdivision map approval or issuance of a certificate of occupancy; or a final art plan must be approved by the City Council before building permit is issued, and the art must be installed before the Certificate of Occupancy is issued. **This form must be submitted with your revised plans.**

Signature of Applicant: [Signature] Date: 09/14/23

For Community Development Department Use:
Estimated Valuation (Subject to revision during Department review) \$ _____
cc. Cultural Arts Department

TLB LLC

TLB LLC Art in Public Places

1369 North Coast Highway Laguna Beach, CA 92651

Artist: Rahul Jhobalia

Title of art piece: Sea Breeze Symphony

Description: “Sea Breeze Symphony” is a dynamic and elegant art sculpture that captures the essence of Laguna Beach. The sculpture consists of multiple stainless steel ribbons or waves flowing in a graceful, interweaving manner. Each ribbon represents a different aspect of Laguna Beach’s character:

- Wave of Nature: one ribbon depicts the undulating curves and forms of ocean waves, symbolizing the city’s stunning coastline and its harmonious relationship with the Pacific Ocean.
- Brushstroke of Artistry: another ribbon takes the form of a paintbrush stroke or a calligraphy brush, representing Laguna Beach’s thriving artistic community and its rich heritage in various art forms.
- Sunbeam of Radiance: A ribbon of curves and twists like a sunbeam, symbolizing the abundant sunshine and the golden light that bathes Laguna Beach, creating a warm and inviting atmosphere.

Note:

The sculpture will be mounted on the wall allowing residents and visitors to appreciate its fluid and captivating design. The stainless steel material ensures durability and reflects the surrounding environment, mimicking the interplay of light on the oceans surface.

Sea Breeze Symphony serves as a tribute to Laguna Beach’s coastal beauty and artistic spirit, inviting viewers to experience the harmony of nature and creativity that defines the city.

Material: the “ribbons” will be made in steel, primed and painted with metallic paint. The “Wave of Nature” will be painted in a turquoise color. The “Brushstroke of artistry” will remain in the steel color and finally the “Sunbeam of Radiance” will be painted in a orange color representing a setting sun

Maintenance: Since the piece will be made in steel and the colors on the piece will be primed and painted, there will be minimal maintenance. The piece will need some dusting which the regular association will take care of but other than that there may be some repainting needed every 5-7 years (if necessary).

9-29-23

AN ELEGANT, DEEP SHIMMERING METALIC SHINING COLOR

82" (6'-10")
SCULPTURE HT.

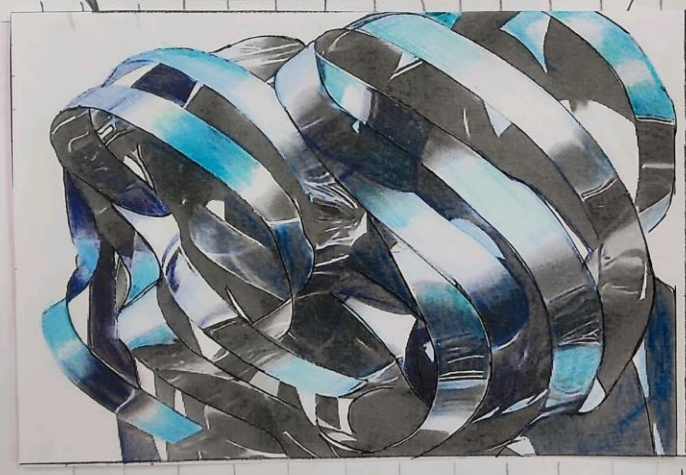

MATERIAL TO BE
COLOR PAINT W/
"METALIC"
EXPOSE SURFACE

6" WIDE WINDING
S/S 22GA. STRAP
TO MAKE
SCULPTURE AS
SLENT.

INSTALL ON
EXISTING CEMENT
SIDING & CONK.
BLOCK WALL

12" | SCULPTURE LENGTH (7'-4") | 12"
112" (9'-4")

FRONT ELEVATION:

SCALE: 3/4" = 1'-0"

(1) P-1

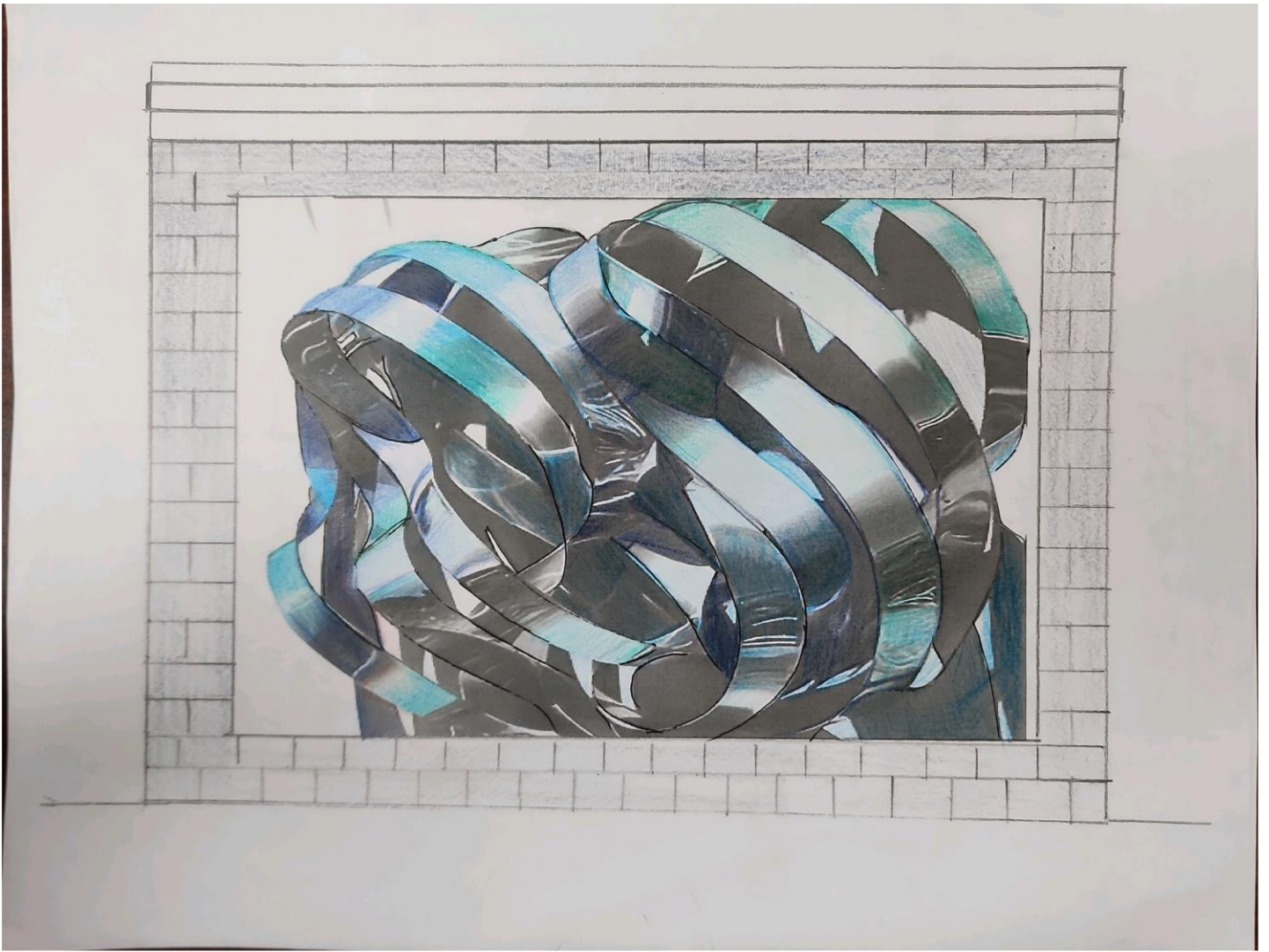

9-29-23.

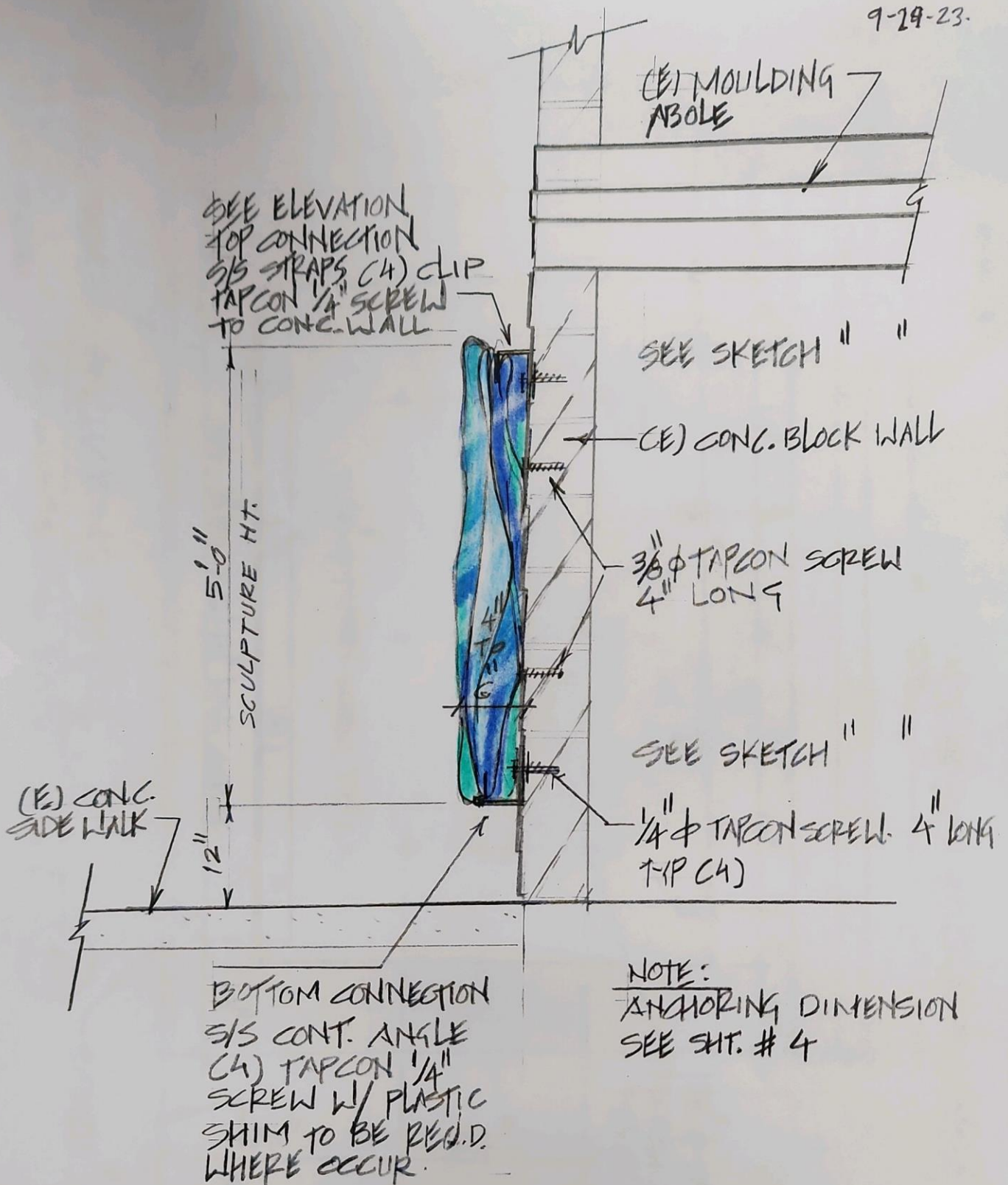

ANCHORING DETAIL
FIELD CONNGTION $3/4" = 1'-0"$

3

P-3

9-14-23

FIELD HOLDING

3/5 STRAP 1/8" THICK TYP. (4)
2" WIDE

SECTION A

3/8" φ TAPCON
SPACED 4" LONG
TYP. (6)

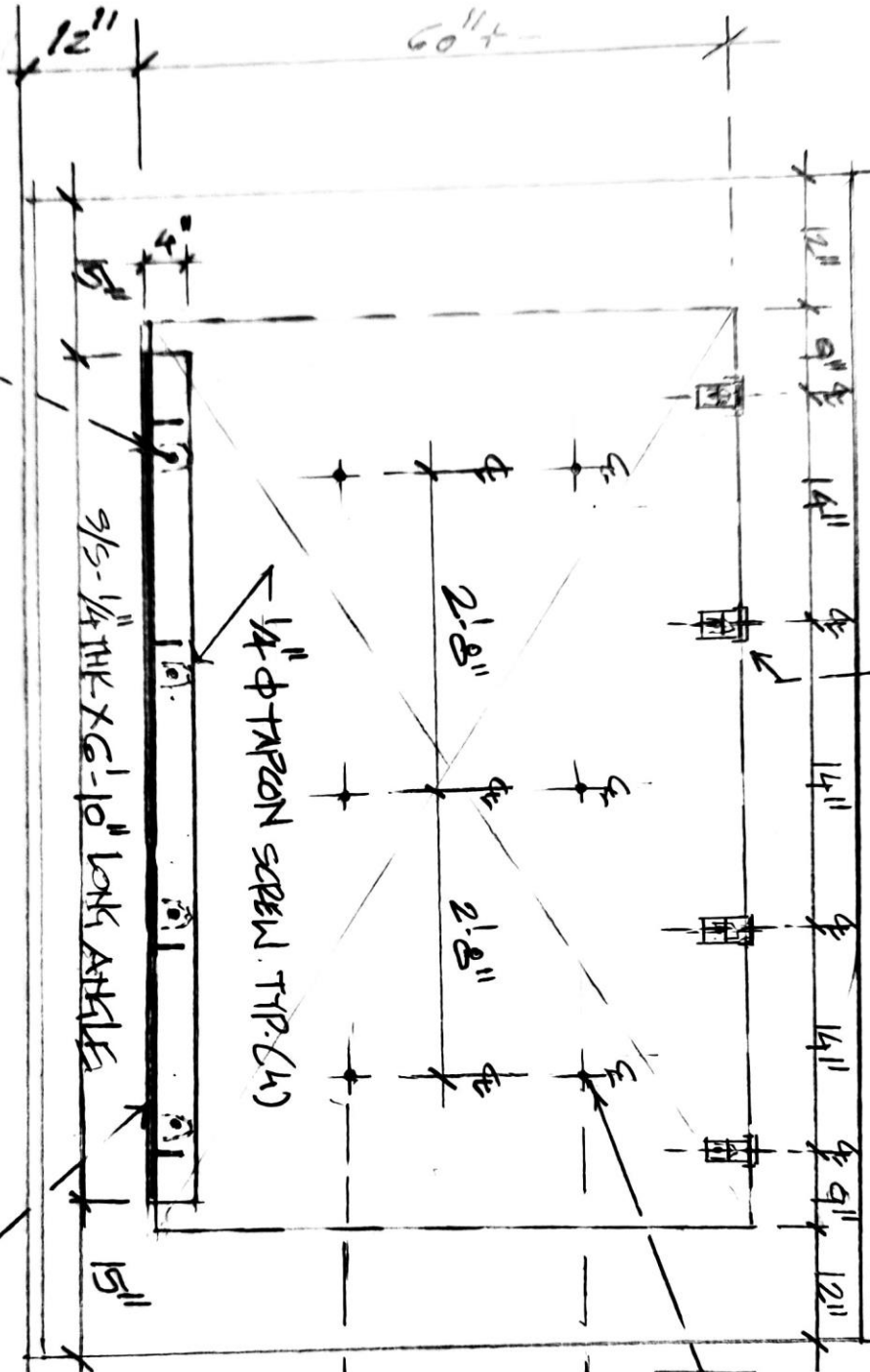

1/2" φ TAPCON SPACED TYP. (4)

3/5-1/4" THICK X 6"-10" LONG ANGLE

FIELD CONNECTION DETAIL
AS SHOWN
WHERE OCCUR

FIELD CONNECTION DETAIL
FIELD CONNECTION DETAIL 3/4" x 1/2"

4

SECTION B

CONCRETE
FINISH

P-4

9-29-23

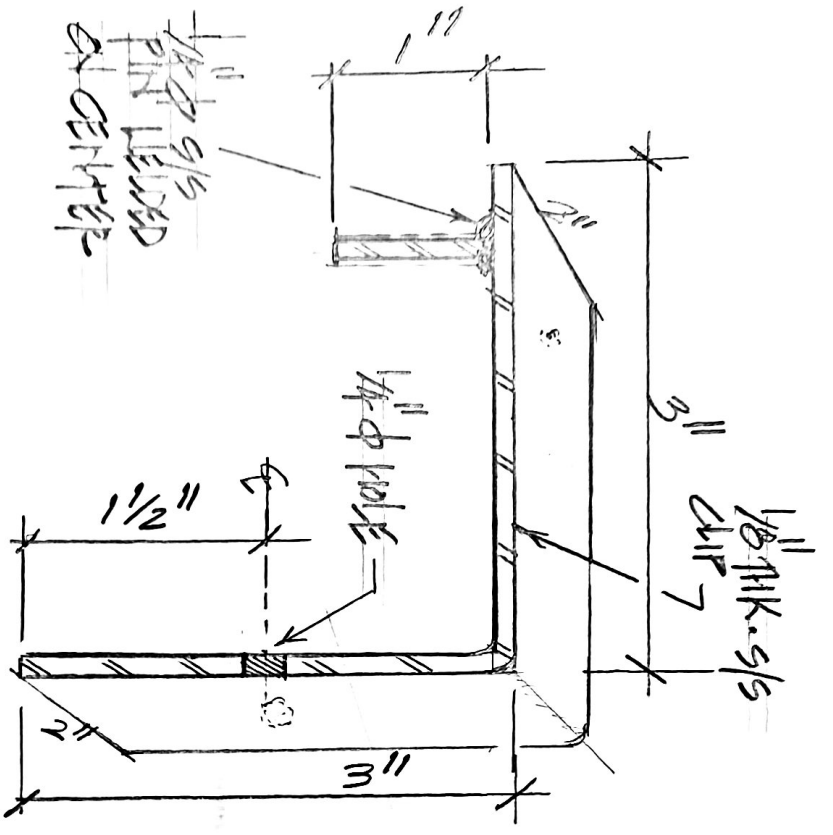

TOP ANCHOR SLIP S/S (4) PER D.T.P.

2 1/2" - 1/4" S/S - 1/8" THK.

SKETCH - "A"

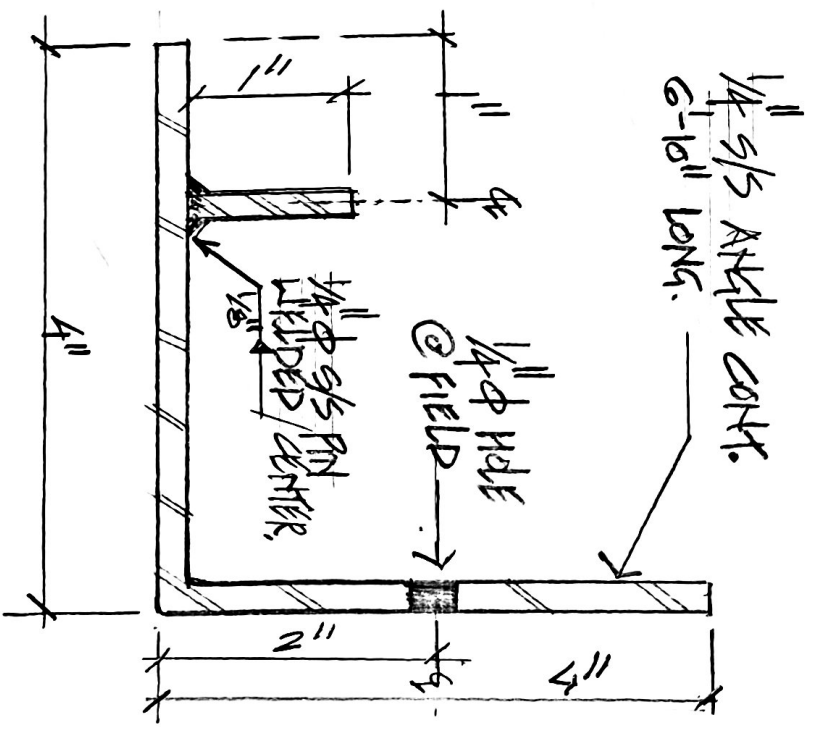

BOTTOM ANCHOR S/S ANGLE CONN.
CID PC PERD.

SKETCH - "B"

P-5

MATERIAL TO BE USED FOR EXTERIOR MODERN SCULPTURE

9-29-2023

- 1 2" WIDE STAINLESS STEEL STRAP 22 GA. TO BENDING
PROCEDURE AS PER SKETCH AND SOME AREA TO WELDED.
- 2 PAINT DESCRIPTION AS FOLLOWS. OF EQUAL CO. TO BE USED.
 - A) STAINLESS STEEL STRAP TO BE 220 GRID SANDING PAPER.
 - B) USE 1ST COAT OF PRIMER SPRAY (PRE-TREATMENT
"MONTANA CANS" # T2300
 - C) USE 2ND COAT OF NC-ACRYLIC EFFECTIVE SPRAY PAINT
"STAINLESS STEEL COLOR EFFECT"
 - D) USE 3RD COAT OF GOLD NC-ACRYLIC PROFESSIONAL-
SPRAY PAINT "MONTANA CANS.
 - E) USE 4TH COAT SYNTHETIC VARNISH TRANSPARENT
PROTECTION SCRATCH RESISTANT "MTM" MONTANA COLOR.

NOTE: ALL ABOVE COMPANY PRODUCT TO USE FOR EXTERIOR
AN ELEGANT MODERN SCULPTURE.

SEE DESIGN, SIZE, ANCHORING SUPPORTS CLIP
ANGLE WITH FASTNERS WITH ATTACHED SHEETS.

EQUAL CO. TO BE USED AS PER OWNER SELECTED.
AND MARKET AVAILABILITY MATERIALS.

P-6

R J RESUME

QUALIFICATION:

1972 to 1976 J.J. school of art Architecture degree in bombay, India
1975 to 1977 Bandra shool of art Interior design degree in Bombay, India
1981 to 1985 Tritone college, Chicago Illinois USA (graduate special subject)

EXPERIENCE:

Self Employee in Bombay, India.
1977 to 1980 Architecture and interior design project for residence building
1974 to 1978 Commercial and Art project for bollywood movie poster with artist.

Employment in California, USA.
1984 to 1990 Architecture project for restaurant design and liquor store design
1991 to 1993 Architecture building and Restaurant design and kitchen design
1993 to 1998 Architecture high Rice building natural stone project in domestic
And las Vegas Casino interior and Exterior projects.

Self Employee in California, USA.
1995 to 2022 Architecture and interior building new and remodels project
for residence and commercial buildings.
2005 to 2022 Personal Art project has been done for temple art and craft works.
Also Public art.

REFERENCES: See attached some certificates and Photograph of Project
Has been done. USA AND CANADA

ADDRESS: RAHUL JHBALIA
8265 Fontainbleau
Cypress ca. 90630

**City of Laguna Beach
Cultural Arts Department
Staff Report**

To: Arts Commission
From: Michael McGregor, Arts Program Coordinator
Meeting Date: October 9, 2023
Agenda Item: 6B
Title: Holiday Palette Competition
Location: Laguna Beach, CA

Overview

The Holiday Palette Competition is open to artists who reside, work, or exhibit in Laguna Beach and are 18 years and older. The painted original artworks adorn lampposts throughout the city during the winter holiday season. Design submissions for the competition were received through October 2, 2023. The Arts Commission has the materials and budget for the selection of up to four (4) designs. Completed palette designs become property of the City of Laguna Beach and are displayed when and where the City desires for up to 7 years or based on its condition.

Summary of the Matter

Design submissions for the 2023 competition can be viewed here:

<https://www.lagunabeachcity.net/home/showdocument?id=16704&t=638319410679591413>

The sub-committee has reviewed the submitted palette designs and may provide an oral recommendation. The Arts Commission will review the submitted designs and may select up to four (4) winning designs to be turned into full-scale 3' x 4' palettes. Selected works should be high quality, original designs. The Commission may decide not to select any submissions.