

**REVOCABLE ENCROACHMENT PERMITS**  
**SUBMITTAL AND PROCESSING REQUIREMENTS**

1. Before an application form is filed, the applicant should discuss the feasibility of the proposed right-of-way encroachment with staff members from the Community Development Department. This class of projects is limited to minor structures such as:

Low fences and retaining walls, walkways, stairs and construction incidentally related to landscape activities such as stepping stones, walking surfaces, planter areas, and irrigation systems but a revocable encroachment permit shall not be used for any structure or improvement that, if demand is made for its removal, will create any nonconforming conditions under the provisions of the Municipal Code or any other Code, regulation or standard.

It is important to note that the City's approval is entirely discretionary and limited to minor types of structures and improvements that will be consistent with all other policies and regulations. Use and maintenance of any encroachment within the public easement is not a right but a privilege extended by the City acting as the custodian of the overall public interest.

2. The application form, which may be obtained at no cost from the Community Development Department, consists of a Revocable License and Encroachment Permit Agreement Form containing four pages. The form must be read carefully and signed by the property owner in the presence of a notary. If approved, the agreement has legal implications for all current and future owners of the property and the owner may wish to consult with an attorney.
3. The information required on the agreement form must be typed or printed clearly in black ink. Page five of the agreement should consist of an 8 ½" x 11" sheet of paper entitled "Encroachment Plan," which must also be drawn clearly and legibly using conventional drafting practices which include the following:
  - A) The plans shall be based upon accurate field measurements at a scale of no less than 1"=20' showing existing gradients and improvements within twenty-five feet of the project area;
  - B) Property lines, easements, drainage patterns and cultural features shall be shown true to scale and dimensions within twenty-five feet of the project area. The complete right-of-way must be identified upon the plan and shall identify the adjacent and opposite edge-of-pavement. In addition, if the property is located within 25 feet of a cul-de-sac, the plan must identify the complete cul-de-sac right-of-way and edge-of pavement;
  - C) Proposed improvements shall be legibly and accurately shown as to line and grade, including surface elevations, wall heights, fence heights, cut/fill slopes and materials;

- D) Proposed improvements shall be legibly and accurately shown as to line and grade, including surface elevations, wall heights, fence heights, cut/fill slopes and materials;
  - E) Grading information shall be shown if applicable. If the proposal involves the grading of more than twenty cubic yards, a geotechnical report is also required.
4. After the Agreement form and accompanying materials have been prepared, they may be submitted to the Community Development Department for review, together with a filing fee, notification list and ownership verification. The mailing list shall be hand delivered or by certified mail, prior to the acceptance of the application forms, directly from a professional listing service. The mailing list must include the addresses and a radius map (8 ½" x 11" paper) of all *property owners* within a 300-foot radius of the subject property, and all *tenants or residents* within 100 feet of the subject property. The address list of labels must be in a 3across by 10-down format on 8-1/2" x 11" paper and include the assessor's parcel number on each address. **The list must be compiled by a professional listing service, utilizing the latest equalized assessment rolls.** A certification letter, signed by a representative of the listing service and attesting to the accuracy of the address list, must be submitted.
  5. Once it has been determined by staff that the application is sufficient and adequate, a hearing date will be set before the Design Review Approval Authority. **AFTER THE APPLICATION HAS BEEN SCHEDULED FOR HEARING, STAFF WILL SEND THE APPLICANT A POSTING NOTICE WHICH IS TO BE POSTED ON THE PROPERTY (10) DAYS PRIOR TO THE PUBLIC HEARING. The posting notice will be sent with a posting affidavit form, which is to be completed and returned prior to the public hearing.**
  6. Public notices will be mailed by staff two weeks prior to the Design Review Approval Authority Hearing date. These meetings are usually convened on the second and fourth Thursdays of every month.
  7. Upon approval by the Design Review Approval Authority, the original copy of the agreement form must be recorded by the applicant before construction may commence. You will be notified when the document is ready for recording, usually within three or four days after the 14-day right-of-appeal period has lapsed.
  8. **The Revocable License and Encroachment Permit Agreement is not a construction permit. A separate construction permit must be obtained for work within the public right-of-way and, in most cases, additional detailed plans showing construction details are required. All work must be in compliance with the approved agreement, permit and plans as verified by field inspection.**
  9. Certain types of work in the public way require the services of licensed and insured contractors. Examples of these activities are mechanical excavations, pipeline and other utility work, construction of concrete and masonry structures and placement of asphalt pavement.

RECORDING REQUESTED BY:  
**City of Laguna Beach**

WHEN RECORDED MAIL TO:  
**City Clerk**  
**City of Laguna Beach**  
**505 Forest Avenue**  
**Laguna Beach, CA 92651**

(Municipality, exempt from SB2 fees  
pursuant to GC 27388.1(a)(2)(D))

SPACE ABOVE THIS LINE FOR RECORDER'S USE

---

**REVOCABLE LICENSE AND ENCROACHMENT PERMIT  
AGREEMENT NO. \_\_\_\_\_**

WHEREAS, the undersigned applicant proposes to construct certain improvements adjacent to the following described parcel of real property in the City of Laguna Beach, County of Orange, State of California, which property has frontage on, to wit:

Street Address: \_\_\_\_\_

Assessor's Parcel Number: \_\_\_\_\_

Legal Description: \_\_\_\_\_

WHEREAS, Applicant desires to use and encroach in, over, upon or under the right-of-way of said street, in constructing, using and maintaining said improvements, to the extent and in the manner hereinafter more specifically described and set forth; and

WHEREAS, the requested encroachment will not, in the opinion of the City of Laguna Beach, obstruct, interfere with, or in any way whatsoever impede or endanger the City or any member of the public in any lawful use of said street as the same is presently improved for public use and a revocable license and encroachment permit can reasonably and safely be granted to the present and future owners of said property for the encroachment hereinafter described until such time when said license and encroachment permit is revoked;

NOW THEREFORE, IN CONSIDERATION OF THE PREMISES and subject to the terms and conditions hereinafter set forth, the City of Laguna Beach does hereby give and grant to Applicant, for the use and benefit of the herein above-described parcel of real property, a revocable license and encroachment permit to construct, keep, use and maintain within the right-of-way where it bounds said parcel of real property, the following described encroachment:

Description of Encroachment:

---

---

---

---

(A map, plat, plot plan, sketch or drawing showing said encroachment is attached hereto, and is referred to herein, and shall be deemed incorporated herein and a part hereto for all purposes.)

**THIS LICENSE AND ENCROACHMENT PERMIT IS EXPRESSLY GRANTED**

**SUBJECT TO THE FOLLOWING TERMS AND CONDITIONS:**

1. Said license and encroachment permit shall run with the parcel of real property as described above and the terms and conditions hereof and all of the duties and liabilities created hereby shall be a benefit to and a burden upon the owners and occupants of the land, their assigns, and their successors in interest;

2. This license and encroachment permit shall be revocable at any time hereafter by the City Council of the City of Laguna Beach with or without cause; provided, however, that before revoking such permit, the City Council shall provide the owner with an opportunity to a hearing after serving at least ten (10) days notice before such hearing; If the City Council exercises its option to revoke this permit and agreement, the permittee and/or any successors, assigns or future holders of interest in the land adjoining the encroachment permit benefit area shall be responsible for the removal at no cost to the City of Laguna Beach of such encroachments and restoration of the terrain within sixty (60) days after written notice of such intention to revoke such license and permit has been served to the owner or occupant of said parcel of real property herein above described. Notice to either the owner or occupant shall be sufficient;

3. That licensee and permittee does hereby, for himself and his successors in interest of said real property, release the City from any and all damage and claim for damage, and does hereby waive any and all actions, causes of action and claims which he or she or they may have, or claim to have, against the City by reason of any future revocation of this license and permit;

4. That licensee and permittee does hereby, understand that a standard condition of approval will be imposed requiring me to defend, hold harmless and indemnify, at my expense, the City, the City Council and other City bodies and members thereof, officials, officers, employees, agents and representatives from and against any and all third-party claims, actions or proceedings to attack, set aside, void or annul the approval, or any associated determination made pursuant to the California Environmental Quality Act, including the City's defense costs

and expenses as well as costs, expenses or damages a court may require the City to pay as a result of such claim, action or proceeding;

5. Licensee and permittee, for himself and his successors in interest, does hereby agree at all times during the life of this license and permit, to carry and maintain in full force and effect comprehensive insurance with such company and in such amounts and upon such terms as shall be acceptable to the City, with the City to be named as one of the insured thereunder so as to protect the City from any and all claims of damage to person or property as a result of the encroachment.

Approved by the Design Review Approval Authority on\_\_\_\_\_.

By: \_\_\_\_\_ Date: \_\_\_\_\_

David Contreras, Director  
Community Development  
City of Laguna Beach

A notary public or other officer completing this certificate verifies only the identity of the individual who signed the document to which this certificate is attached, and not the truthfulness, accuracy, or validity of that document.

State of California}  
County of Orange} ss.

On this \_\_\_\_\_ day of \_\_\_\_\_, 20 \_\_\_\_\_, before me, \_\_\_\_\_,

a Notary Public, personally appeared David Contreras, who proved to me on the basis of satisfactory evidence to be the person whose name is subscribed to the within instrument and acknowledged to me that he executed the same in his authorized capacity, and that by his signature on the instrument the person, or the entity upon behalf of which the person acted, executed the instrument.

I certify under PENALTY OF PERJURY under the laws of the State of California that the foregoing paragraph is true and correct.

WITNESS my hand and official seal.

\_\_\_\_\_  
Notary's Signature

I hereby represent that I am the owner of the above-described property, and, after reviewing the foregoing terms and conditions, I accept this Revocable License and Encroachment Permit and agree that I have applied for the same and that I have read and know the contents thereof and for myself and my successors in interest, as owners or occupants of the parcel of land herein above described, I agree to abide by and be bound by all the terms, conditions and provisions thereof.

Dated \_\_\_\_\_, 20\_\_

_____ Name of Owner(s)	_____ Name of Owner(s)
_____ Address of Owner(s)	_____ Address of Owner(s)
_____ Signature of Owner(s)	_____ Signature of Owner(s)

A notary public or other officer completing this certificate verifies only the identity of the individual who signed the document to which this certificate is attached, and not the truthfulness, accuracy, or validity of that document.

State of California }  
County of Orange } ss.

On this \_\_\_ day of \_\_\_\_\_, 20\_\_, before me, \_\_\_\_\_,

a Notary Public, personally appeared \_\_\_\_\_,  
who proved to me on the basis of satisfactory evidence to be the person(s) whose name(s) is/are subscribed to the within instrument and acknowledged to me that he/she/they executed the same in his/her/their authorized capacity(ies), and that by his/her/their signatures(s) on the instrument the person(s), or the entity upon behalf of which the person(s) acted, executed the instrument.

I certify under PENALTY OF PERJURY under the laws of the State of California that the foregoing paragraph is true and correct.

WITNESS my hand and official seal.

\_\_\_\_\_  
Notary's Signature

# Encroachment Plan Example

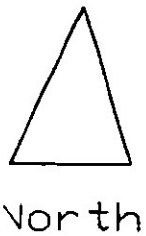

EXAMPLE

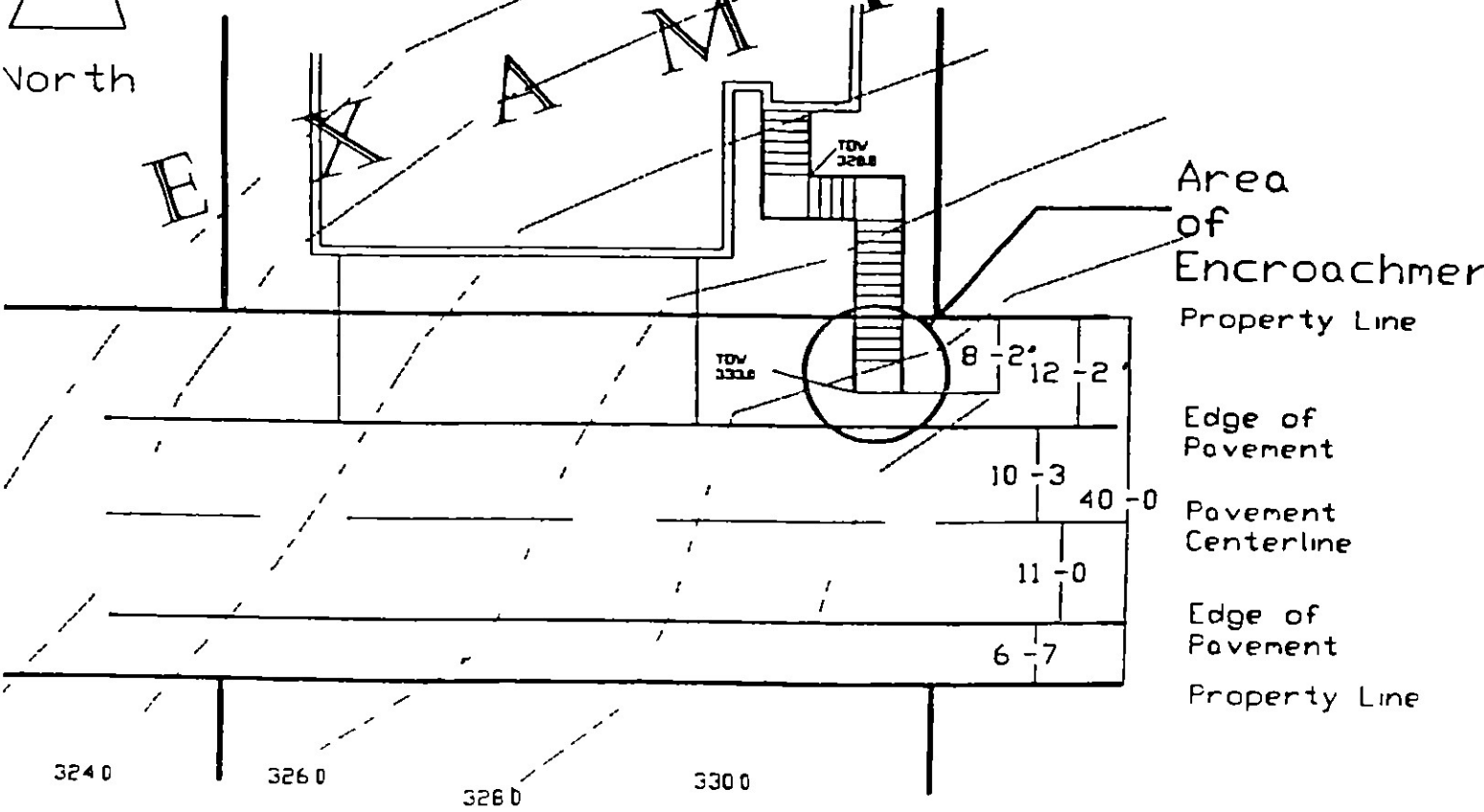

Scale 1/20